

DATA SHEET

SUNGMUN CODE : E5E8-2.9S8-6B15

DESCRIPTION : Encoder

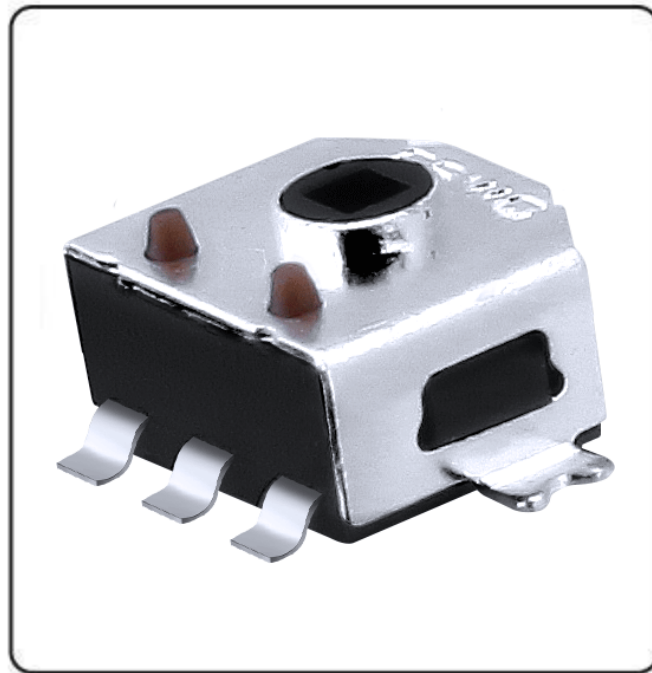

帝凡芯城
Dicomon.com



F-SWITCH ELECTRONICS CO.,LTD.

名称 TITLE	ENCODER	料号 PART NO.	E5E8-2.9S8-6B15	图号 DRAWING NO.	FSE5-WI-DR-004
规格 SPEC	4.8×3.8×2.8mmSMT平贴型编码器, 安装高度2.9mm, 四方孔径0.8mm, 扭力8gf, 6脉冲12定位, 标准齿感, 寿命10万次				

No.	Items	Standard	No.	Items	Standard
1(1.2)	Operating Temperature Range	-40°C to +85°C	19(7.1)	Mechanical Life	100,000 cycles(30 t/min, Torque attenuation <30%)
2(1.3)	Operating Relative Humidity	≤85% RH	20(7.2)	Electronics Life	100,000 cycles(30 t/min, Torque attenuation <30%)
3(3)	Ratings	DC 5V 0.5mA	21(8.1)	Cold Proof	-40±2°C 96h
4(4.1)	Contact Resistance	200mΩ Max(Initial status).	22(8.2)	Hot Proof	85±2°C 96h
5(4.2)	Insulation Resistance	10MΩ Min.	23(8.3)	Moisture Resistance	40±2°C, 90-95%RH 96h
6(4.3)	Dielectric Voltage	AC50V, 60s	24(8.4)	Temperature Cycling	-40~85°C, change 5 cycles
7(4.4)	Output signal format	C.W. 6pulse/360°, A(A~C), B(B~C)	25(8.5)	Salt Mist	5% NaCl 24h(Cut surface exemption)
(5.2)		C.C.W. 6pulse/360°, B(B~C), A(A~C)	26(8.6)	Vulcanization test	3% Na2S 3 minutes(Cut surface exemption)
8(4.4)	Phase-different	T1,T2,T3,T4 ≥ 4mS	Dimensions:		
9(4.5)	Chattering	t1,t3 ≤ 3mS	1	Solder foot width	6.8±0.2
10(4.5)	Bounce	t2 ≤ 2mS	2	Top height	1.75 ⁺⁰ _{-0.1}
11(5.1)	Detent points	12detent points, each angle:30°±3°	3	Body thickness	2.85±0.2
12(5.3)	Rotational force	8±5gf.cm (Initial status)	4	Width of Pin	0.6±0.1
13(5.4)	Tooth Intensity Value	/	5	Flatness	0 ^{+0.1} _{-0.05}
14(5.4)	Tooth sense consistency	/	6	Distance of column	3.5±0.1
15(5.5)	Axial Swing Strength	1N, 60S	7	Distance of square hole to column	1.8±0.1
16(5.6)	Terminal Strength	1N, 10S.	8	Column Size	0.5±0.05
17(6.2)	Solder Heat Resistance	SMT Soldering 245°C Max 3S Max, 230°C Min 30S Max	9	Square Hole Size	0.8±0.02
		Manual Soldering 350°C Max, 3S Max			
18(6.1)	Solder Ability	245°C Max, 3S Max			

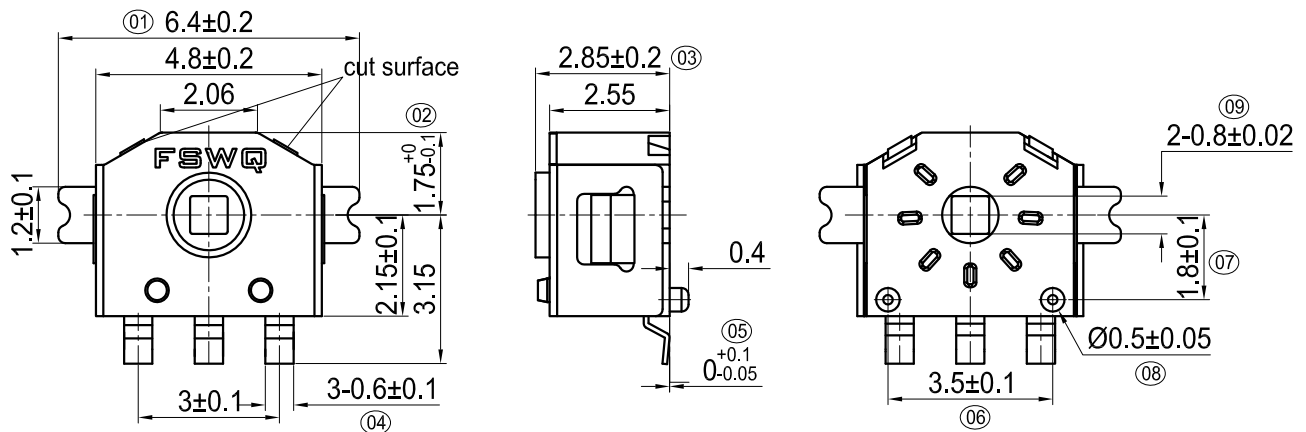

(Tolerance: ±0.1)
(P.C.B thickness t=0.3~0.5)

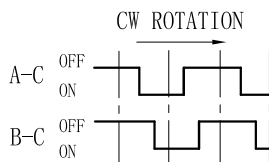
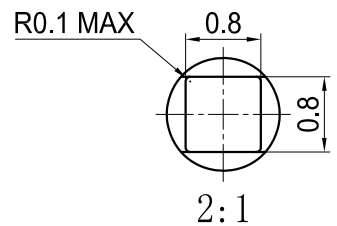
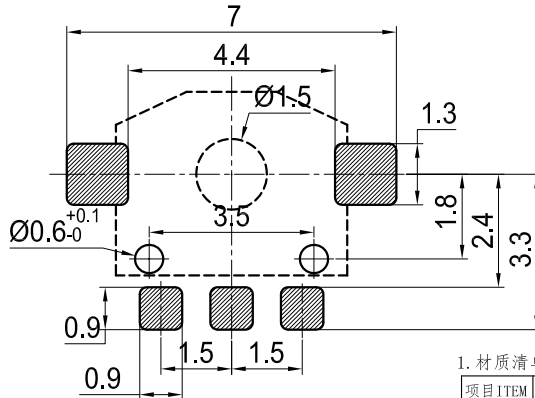
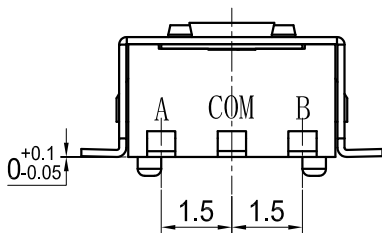

6 pulse 12 click

1. 材质清单 Material list

项目 ITEM	名称 Name	材质 MATERIAL
1	盖片 Cover	铜合金 Copper alloy
2	定位片 Anchor Plate	不锈钢 Stainless Steel Strips
3	齿轮 Wheel gear	工程塑料
4	底座 Base	工程塑料(黑色)
5	接触片 Contact Spring	铜合金 Copper alloy
6	端子 Terminal	铜合金 Copper alloy

VER.	内容 S.U.B.	修改 MODIFY	日期 DATE	公差 TOLERANCE	单位 UNIT	张数 SHEET	图幅 SIZE	图类 TYPE
①				L<5 ±0.2	mm	1/1	A4	成品图
②				L<10 ±0.3	版本 REV.	设计 DSGD.	审核 CHKD.	核准 APPD.
③				L<30 ±0.5	比例 SCALE			
④				.X° ±2° X.° ±5° 角法 P R O J.	12:1			