

DATA SHEET

SUNGMUN CODE : E8A5-5.5C20-9B15

DESCRIPTION : Encoder



帝凡芯城
Dicomon.com



F-SWITCH ELECTRONICS CO.,LTD.

名称 TITLE	ENCODER	料号 PART NO.	E8A5-5.5C20-9B15	图号 DRAWING NO.	FSE8-WI-DR-019
规格 SPEC	立式SMT型, 7.8×3.8mm編碼器, 安裝高度5.5mm, 孔徑1.74mm, 扭力20gf, 9脉冲18定位, 標準齒感, 壽命10萬次or20萬圈				

No.	Items	Standard	No.	Items	Standard
1(1.2)	Operating Temperature Range	-40°C to +85°C	19(7.1)	Mechanical Life	100,000 cycles(30 t/min, Torque attenuation <30%)
2(1.3)	Operating Relative Humidity	≤85% RH	20(7.2)	Electronics Life	100,000 cycles(30 t/min, Torque attenuation <30%)
3(3)	Ratings	DC 5V 0.5mA	21(8.1)	Cold Proof	-40±2°C 96h
4(4.1)	Contact Resistance	200mΩ Max(Initial status).	22(8.2)	Hot Proof	85±2°C 96h
5(4.2)	Insulation Resistance	50MΩ Min.	23(8.3)	Moisture Resistance	40±2°C, 90-95%RH 96h
6(4.3)	Dielectric Voltage	AC50V, 60s	24(8.4)	Temperature Cycling	-40~85°C, change 5 cycles
7(4.4)	Output signal format	C.W. 9pulse/360°,A(A~C),B(B~C)	25(8.5)	Salt Mist	5% Nacl 24h
(5.2)		C.C.W. 9pulse/360°,B(B~C),A(A~C)	26(8.6)	Vulcanization test	3% Nazs 3 minutes
8(4.4)	Phase-different	T1,T2,T3,T4 ≥ 4mS	Dimensions:		
9(4.5)	Chattering	t1,t3 ≤ 3mS	1	Body width	7.8±0.2mm
10(4.5)	Bounce	t2 ≤ 2mS	2	Top height	3.45±0.2mm
11(5.1)	Detent points	18 detent points,each angle:20°±3°	3	Use height	5.5±0.1mm
12(5.3)	Rotational force	20±8gf.cm (Initial status)	4	Width of mounting feet	7.54±0.3mm
13(5.4)	Tooth Intensity Value	≥70%	5	Width of cover feet	1.2±0.1mm
14(5.4)	Tooth sense consistency	≤35%	6	Width of Pin	1.0±0.1mm
15(5.5)	Axial Swing Strength	100gf, 60S	7	mounting foot distance	0.8±0.1mm
16(5.6)	Terminal Strength	3N, 10S.	8	Width of cover feet	1.2±0.1mm
17(6.2)	Solder Heat Resistance	Dip Soldering 255°C Max 3S Max, 230°C Min 30S Max	9	Hexagon size	1.74±0.02mm
		Manual Soldering 350°C Max, 3s Max			
18(6.1)	Solder Ability	255°C Max, 3S Max			

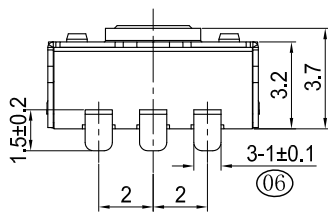
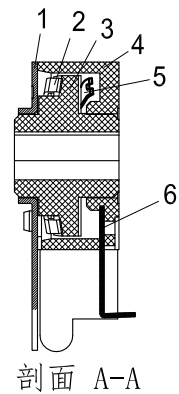
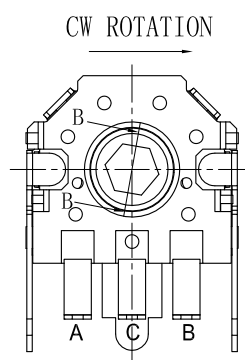
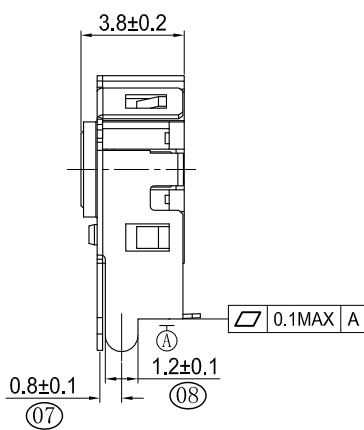
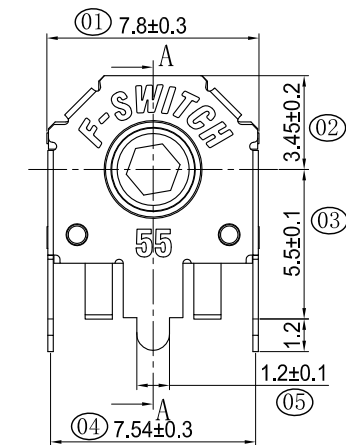

Shaft hole shape and dimension

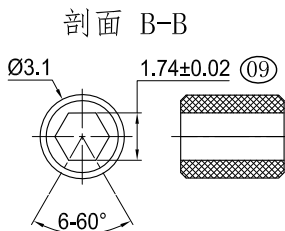

(Tolerance: ±0.1)
(P. C. B thickness $\tau=1.0, 1.2$)

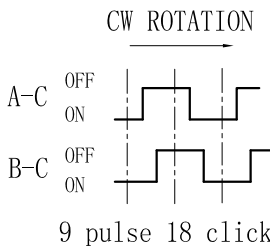
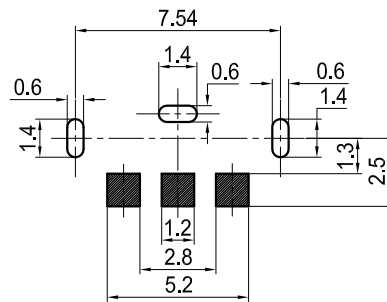

9 pulse 18 click

1. 材质清单 Material list

项目 ITEM	名称 Name	材质 MATERIAL
1	盖片 Cover	SUS301
2	定位片 Anchor Plate	不锈钢 Stainless Steel Strips
3	齿轮 Wheel gear	工程塑料(PA46)
4	底座 Base	工程塑料(PA46)棕色
5	接触片 Contact Spring	磷铜合金 Copper alloy
6	端子 Terminal	铜合金 Copper alloy

VER.	内容 S. U. B.	修改 MODIFY	日期 DATE	公差 TOLERANCE	单位 UNIT	张数 SHEET	图幅 SIZE	图类 TYPE
①				L<5	±0.2	mm	A4	成品图
②				L<10	±0.3	版本 REV.	设计 DSGD.	审核 CHKD.
③				L<30	±0.5	A0		核准 APPD.
④				.X° ±2° 角法 P R O J.	X.° ±5°	比例 SCALE		