

# DATA SHEET

SUNGMUN CODE : E12F7-10M60-20T54-F500

DESCRIPTION : Encoder



帝凡芯城  
Dicomon.com



# F-SWITCH ELECTRONICS CO.,LTD.

名称 TITLE	ENCODER	料号 PART NO.	E12F7-10M60-20T54-F500	图号 DRAWING NO.	FSE11-WI-DR-007
规格 SPEC	立式PCB型, 11.8*12*4.5mm 编码器, 安装高度10.0mm, 轴径6.0mm, 扭力60gf, 开关按力500gf, 20脉冲20定位, 寿命10万次.				

No.	Items	Standard	No.	Items	Standard
1(1.2)	Operating Temperature Range	-40°C to +85°C	19(7.1)	Mechanical Life	50,000 cycles(30 t/min, Torque attenuation <30%)
2(1.3)	Operating Relative Humidity	≤85% RH	20(7.2)	Electronics Life	50,000 cycles(30 t/min, Torque attenuation <30%)
3(3)	Ratings	DC 12V 0.5mA	19(7.3)	Switch Mechanical Life	50,000 cycles(60 t/min, Torque attenuation <30%)
4(4.1)	Contact Resistance	200mΩ Max(Initial status )	20(7.2)	Switch Electronics Life	50,000 cycles(60 t/min, Torque attenuation <30%)
5(4.2)	Insulation Resistance	50MΩ Min.	21(8.1)	Cold Proof	-40±2°C 96h
6(4.3)	Dielectric Voltage	AC50V · 60s	22(8.2)	Hot Proof	85±2°C 96h
7(4.4)	Output signal format	C.W. 20pulse/360°,A(A~C),B(B~C)	23(8.3)	Moisture Resistance	40±2°C · 90-95%RH 96h
(5.2)		C.C.W. 20pulse/360°,B(B~C),A(A~C)	24(8.4)	Temperature Cycling	-40~85°C · change 5 cycles
8(4.4)	Phase-different	T1,T2,T3,T4 ≥ 4mS	25(8.5)	Salt Mist	5% NaCl 24h
9(4.5)	Chattering	t1,t3 ≤ 3mS	26(8.6)	Vulcanization test	3% Na2s 3 minutes
10(4.5)	Bounce	t2 ≤ 2mS	Dimensions:		
11(5.1)	Detent points	20 detent points,each angle:20°±3°	1	11.8±0.2mm	12 5-0.8±0.1mm
12(5.3)	Rotational force	60±20gf.cm (Initial status )	2	Ø6.0 <sup>+0</sup> <sub>-0.05</sub> mm	
12(5.3)	Push force	500±150gf (Initial status )	3	12.0±0.2mm	
12(5.3)	Restoring force	80gf (Initial status )	4	4.5 <sup>+0</sup> <sub>-0.05</sub> mm	
13(5.4)	Axial lateral push Strength	25N, 10S.	5	0.5±0.3mm	
14(5.4)	Axial pull Strength	50N, 10S.	6	3.5±0.1mm	
15(5.5)	Axial Swing Strength	3N, 60S. Axial Swing <0.3mm	7	10.0±0.2mm	
16(5.6)	Terminal Strength	3N, 10S.	8	2.0±0.1mm	
17(6.2)	Solder Heat Resistance	Wave Soldering 260°C Max, 5S Min	9	7.0±0.3mm	
		Manual Soldering 350°C Max, 3s Max	10	7.5±0.3mm	
18(6.1)	Solder Ability	260°C Max, 3S Min	11	13.6±0.3mm	

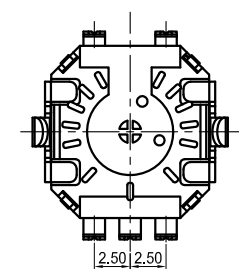
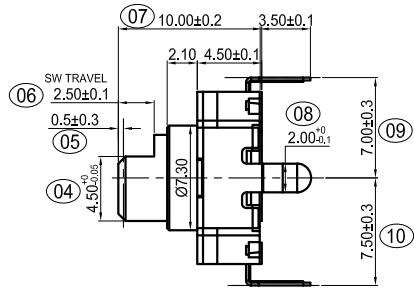
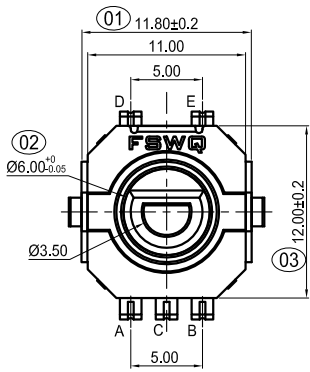

(Tolerance: ±0.1)  
(P.C.B thickness t=1.6~2.0)

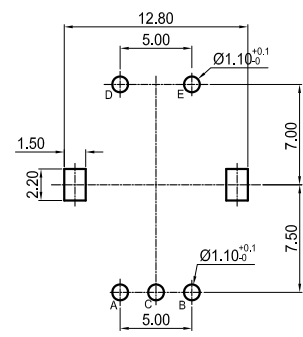
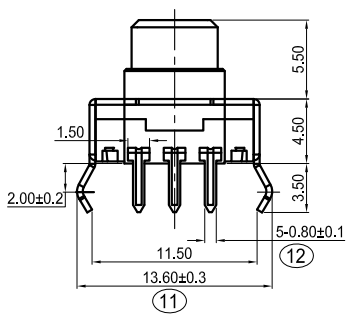
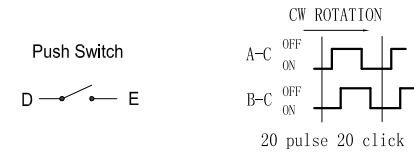

### 1. 材质清单 Material list

项目 ITEM	名称 Name	材质 MATERIAL
1	转轴 Shaft	工程塑料(PC)
2	盖片 Cover	铁片 SPCC
3	定位片 Anchor Plate	不锈钢 Stainless Steel Strips
4	齿轮 Wheel gear	工程塑料(PA66)
5	接触片 Contact Spring	磷铜合金 Copper alloy
6	底座 Base	工程塑料(PA66)
7	端子 Terminal	磷铜合金 Copper alloy
8	弹片 Spring	不锈钢 Stainless Steel Strips
9	轴套	工程塑料(PA66)

VER.	内容 S.U.B.	修改 MODIFY	日期 DATE	公差 TOLERANCE	单位 UNIT	张数 SHEET	图幅 SIZE	图类 TYPE
10				L<5 ±0.2	mm	1/1	A4	成品图
				L<10 ±0.3	版本 REV.	设计 DSGD.	审核 CHKD.	核准 APPD.
				L<30 ±0.5	A2			
				.X° ±2° X.° ±5°	比例 SCALE			
				角法 PROJ.	5:1			