

REV NO.	DATE	REVISION	DR	CH	APP

SPECIFICATION

1. Rating : DC12V 0.5A~24V 0.3A.
2. Contact Resistance : 30mΩ Max.
3. Travel : 1.6mm.
4. Operating Force : 250 ± 150gf.
5. Life Cycle : 2,000 Cycle (with load).
6. Packing : 200pcs Vinyl Bag

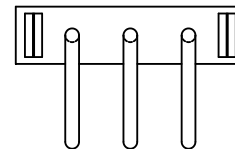
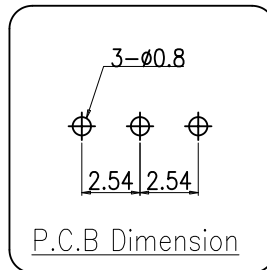
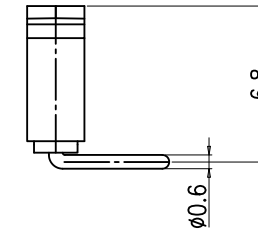
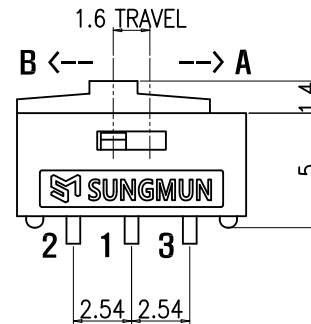
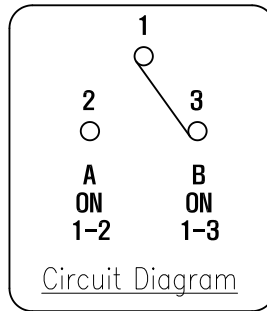
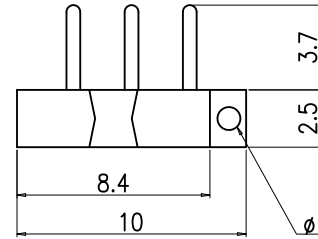

DRAW/DESIGNED	CHECKED	APPROVED	UNIT	G.TOL	TITLE	MINI SLIDE SWITCH	
K.N KIM	W.J LEE	K.I LEE		mm	±0.3	SCALE	MODEL NO.
2022-10-19	2022-10-19	2022-10-19	mm	3:1	SIZE	SSI-10H-ORO	01
SUNG MUN ELECTRONICS CO.,LTD				A4	DRAW NO.	SSI-10H-ORO-01	01

REV NO.	DATE	REVISION	DR	CH	APP
△	22.10.11	모델명 변경(BSI->SSI) 및 색상코드 & 성문 로고 추가	K.N KIM	W.J LEE	K.I LEE

MINI SLIDE SWITCH CODE [SSI-10 TYPE]

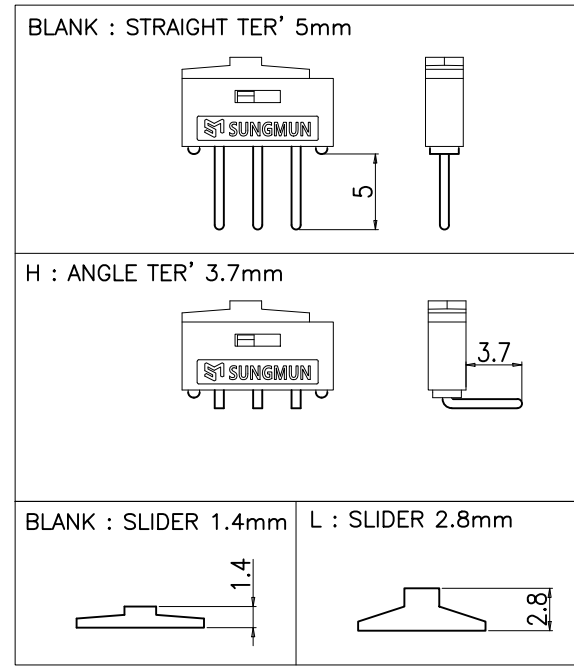
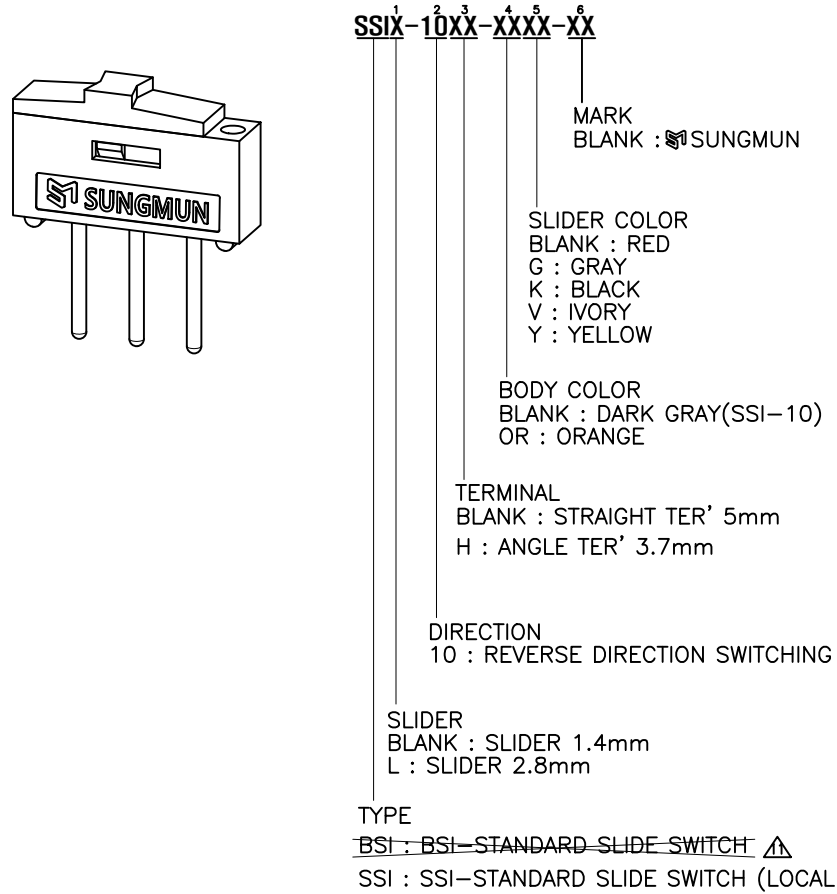

01	-		-		-		-	
NO.	DESCRIPTION			MATERIAL		COLOR / FINISH		REMARK
	DRAW/DESIGNED	CHECKED	APPROVED	 G.TOL ±0.3	TITLE	MINI SLIDE SWITCH		REV.
	S.M PARK	W.J LEE	K.I LEE			UNIT	MODEL NO.	
	2019-11-01	2019-11-01	2019-11-01	mm	SCALE	SSIX-10XX-XXXX-XX-11		11
	SUNGMUN ELECTRONICS CO.,LTD			SIZE	DRAW NO.	SSIX-10XX-XXXX-XX-11		11
				A4				

1. Electrical Characteristics :

- 1.1 Rating : AC, DC 12V 0.5A~24V 0.3A (Minimum current: 1mA)
- 1.2 Contact Resistance : Max 30 mΩ
- 1.3 Insulation Resistance : Min 10,000 MΩ at DC 500V
- 1.4 Withstanding Voltage : 1min at AC 500V

2. Mechanical Characteristics :

- 2.1 Operating Force : 250gf ± 150gf
- 2.2 Travel : 1.6mm
- 2.3 Insulator :
 - 2.3.1 Case : Glass Fiber resin
 - 2.3.2 Slide : Glass Fiber resin
- 2.4 Terminal : Nickel, Gold Plate

3. Life Test :

- 3.1 Test Condition : Operations at a rate of 15-20 cycles in 1 minute
 - 3.1.1 With load : 2,000 cycles
 - 3.1.2 Without load : 10,000 cycles
- 3.2 Operating Force : With +40%, -40% of Initial Value
- 3.3 Contact Resistance : Max 200mΩ

4. Environmental Characteristics :

- 4.1 Operating Temperature : -40°C to +85°C
- 4.2 Storage Temperature : -40°C to +85°C
- 4.3 Humidity Test :
 - 4.3.1 Test Conditions : Measured 1hour after exposure to ambient
After 96hours exposure at 40±2°C, 90-95%R.H
 - 4.3.2 Insulation Resistance : Min 100MΩ, at DC 500V
 - 4.3.3 Withstanding Voltage : 1min at AC 250V

5. Solder Conditions :

- 5.1 Hand Solder : 3~4 sec. at 350°C
- 5.2 Wave Solder : 5 sec. at 260°C